

Operating instructions (original) Water management system C 400 V

Type 557, 558, 562



	deconta GmbH Im Geer 20 46419 Isselburg	Phone: 02874/9156-0 Fax: 02874/9156-11 E-mail: info@deconta.com Web: www.deconta.com	Language: EN
			Version: 2
			Issue Date:
			30.04.2025

1	Product and manufacturer	5
1.1	Product.....	5
1.2	Manufacturer	5
1.3	Change index	5
2	About these operating instructions.....	6
2.1	Purpose.....	6
2.2	Availability	6
2.3	Warnings.....	7
	2.3.1 Warning words and warning colours	7
	2.3.2 Structure	7
2.4	Symbols	8
	2.4.1 Warning sign.....	8
	2.4.2 Instruction sign	8
3	Description of the machine	9
3.1	General description	9
	3.1.1 Sewage pump.....	9
	3.1.2 Version with 2 waste water pumps.....	9
	3.1.3 Version with control compulsory locking	9
	3.1.4 Instantaneous water heater	10
3.2	Scope of delivery.....	10
3.3	Return delivery after termination of a lease	10
3.4	Operating modes.....	11
	3.4.1 Available operating modes.....	11
3.5	Interfaces	11
3.6	Type plate	12
	3.6.1 Version	12
	3.6.2 Position.....	12
3.7	Accessories.....	12
4	Technical data.....	13
5	Security	14
5.1	Intended use	14
5.2	Misapplication	15
5.3	Tasks and qualifications of the staff.....	16
5.4	Notes on occupational health and safety	17
6	Transport.....	18
6.1	Loss of warranty claims	18
6.2	Off-site transport.....	18
	6.2.1 Transport space.....	18
	6.2.2 Legislation	18
	6.2.3 Qualification of the staff	19
	6.2.4 Warning of residual risks.....	19
	6.2.5 Means of transportation	19

6.3	Internal transport	19
6.3.1	Transport space.....	19
6.3.2	Legislation	19
6.3.3	Warning of residual risks.....	19
6.3.4	Means of transportation	20
7	Assembly.....	21
8	Put into operation	21
8.1	Version with one wastewater pump / with forced locking	22
8.2	Version with 2 wastewater pumps for 2nd shower	23
8.3	Version with control compulsory locking	25
8.3.1	Switching on the positive locking	25
9	Operation.....	26
9.1	Qualification of the staff	26
9.2	Warning of residual risks	26
9.3	Personal protective equipment required	27
9.4	Number of persons	27
9.5	Tools needed	27
9.6	Required equipment.....	27
9.7	Commissioning after triggering the safety temperature and pressure limiter	28
10	Maintenance.....	29
10.1	Loss of warranty claims	29
10.2	Maintenance.....	29
10.2.1	Warning of residual risks.....	29
10.2.2	Personal protective equipment required.....	30
10.3	Daily maintenance.....	30
10.4	Filter change	30
11	Spare parts.....	32
11.1	Water management system C 400 V Type 557	32
11.2	Water management system C 400 V Type 558 with positive locking	33
11.3	Water management system C 400 V type 562 with 2 wastewater pumps	34
12	Circuit diagrams	35
12.1	Water management system C 400 V Type 557	35
12.2	Water management system C 400 V type 558 with forced locking	36
12.3	Water management system C 400 V type 562 with 2 wastewater pumps	37
13	Cleaning	38
14	Storage	38
15	Disposal	39
15.1	Qualification of the staff	39
15.2	Legislation	39
15.3	Waste.....	39
16	EC Declaration of Conformity	40

1 Product and manufacturer

1.1 Product

This operating manual describes the following product:

Water management system C 400 V.

Serial number:

1.2 Manufacturer

Name and address	deconta GmbH Im Geer 20 46419 Isselburg
	
Phone	02874/9156-0
Fax	02874/9156-11
E-mail	info@deconta.com
Internet	www.deconta.com

1.3 Change index

Date	Version	Change	Responsible
27.04.2023	2	complete revision	Thomas Boland

2 About these operating instructions

For proper and safe use of the machine, follow the descriptions and recommended actions in these operating instructions.

Keep this manual for future reference until the machine has been disposed of.

2.1 Purpose

These operating instructions contain information on the safe, trouble-free and economical use of the machine.

This information is intended for persons who perform tasks with or in connection with the machine.

The following table gives an overview of persons and tasks.

Person	Task
Operator	<< Machine-specific >>
Occupational safety specialist	<ul style="list-style-type: none"> • Carry out a risk assessment • Create operating instructions • Instruct people
Maintenance staff	Maintenance of the mechanics
Electrician (EFK)	Installation and maintenance of electrical equipment
Freight forwarder	Off-site transport of the machine
Conveyor	Internal transport of the machine
Disposer	Dispose of the machine in a legally compliant, proper and professional manner.

2.2 Availability

The operator shall make these operating instructions or extracts thereof available to persons who perform tasks with or in connection with the machine.

The operator keeps these operating instructions or extracts thereof within easy reach in the immediate vicinity of the machine.

When handing over the machine to another person, the operator passes these operating instructions on to that person.





2.3 Warnings

These operating instructions contain warnings of residual dangers.

The classification of the warnings is based on the severity of the damage that can occur if the warnings are disregarded and recommended actions are not followed.

2.3.1 Warning words and warning colours

Warnings are introduced with one of the following warning words and marked with a corresponding warning colour.

Warning word	Meaning	Warning colour
DANGER	Consequence for non-compliance: Death or most serious injuries.	
WARNING	Consequence for non-compliance: Death or most severe injuries possible.	
CAUTION	Consequence for non-compliance: Severe or minor injuries possible.	
NOTE	Consequence for non-compliance: Property damage or environmental damage possible.	
SAFE ACTIVITY	Implement the following action guide.	-

2.3.2 Structure

Warnings are structured according to the SAFE method:

S	Warning word (DANGER; WARNING, CAUTION or NOTE)
A	Nature and source of the hazard Description of the hazard and the cause of the hazard
F	Follow Description of the possible consequences for humans, animals and the environment that may occur as a result of the hazard.
E	Escape Recommendations for action on how to avoid hazards



2.4 Symbols

The following symbols are used in these operating instructions.

2.4.1 Warning sign

The warning sign is a safety sign that warns of a risk or danger.



The following table gives an overview of warning signs used and their meaning.

Symbol	Meaning	Symbol	Meaning
	Warning of electrical voltage		General warning sign
	Hot surface warning Danger of scalding		

2.4.2 Instruction sign

The instruction sign is a safety sign that prescribes a certain behaviour.

The following table gives an overview of the instruction signs used and their meaning.

Symbol	Meaning	Symbol	Meaning
	Wear safety shoes		Use protective clothing
	Use hearing protection		

3 Description of the machine

This section contains information for understanding the machine.

3.1 General description

General description of the product

The Water management system was designed and built by deconta GmbH, Im Geer 20, 46419 Isselburg.

The deconta Water management system C 400 V provides for the heating of the shower water and takes over the treatment (filtering) of the contaminated waste water.

The electronic flow heater, the waste water pump and a 3-stage waste water filter system are accommodated in the powder-coated aluminium housing.

The hot water output temperature of the shower water is infinitely variable with a maximum flow rate of 10 litres per minute.

3.1.1 Sewage pump

The self-priming wastewater pump is installed ready for operation in the Water management system. It sucks the contaminated shower water through the pre-filter and then pumps it through the two fine filters. During showering, an automatic system ensures that the pump is started and runs during the entire process. Manual starting is possible by pressing the "waste water pump start" button.

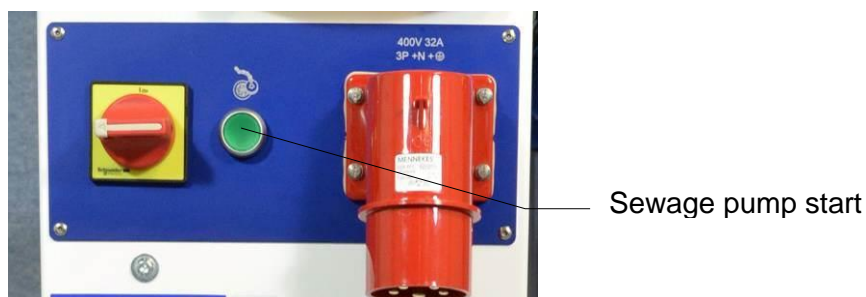

3.1.2 Version with 2 waste water pumps

The Water management system C 400 V can be equipped with a second waste water pump. This sucks the contaminated shower water through a separate pre-filter in parallel with the first waste water pump and then pumps it through the two common fine filters. A typical application is a 5-chamber airlock with two shower chambers.

3.1.3 Version with control compulsory locking

In this version, the control for the forced locking and forced showering of the deconta personal lock is integrated in the Water management system.

3.1.4 Instantaneous water heater

The instantaneous water heater is fully electronically controlled and heats the water as it flows through. The electronic regulation and control unit records the water flow rate, the inlet temperature and the outlet temperature specified on the temperature selector knob. The microprocessor calculates the required value from this and switches on the corresponding heating power. When the hot water valve is closed, the heating is switched off automatically. The unit essentially consists of the heating block, the power module, the electronic module and a safety temperature and pressure limiter.

Procedure for carrying out the risk assessment for machinery

- Language of the risk assessment: German
- Risk assessment: EN ISO 12100 Safety of machinery - General principles for design - Risk assessment and risk reduction, three-step iterative process for risk reduction in conjunction with Machinery Directive 2006/42/EC, Annex I, first general principle.
- Risk assessment: DIN ISO/TR 14121-2 Safety of machinery - Risk assessment - Part 2: Practical guide and examples of procedures, 6.3 Risk graph; Determination of the required performance level (PLr): EN ISO 13849-1 Safety of machinery - Safety-related parts of control systems - Part 1: General principles for design; Determination of SIL (Safety Integrity Level): EN 62061 Safety of machinery - Functional safety of safety-related electrical, electronic and programmable electronic control systems.

3.2 Scope of delivery

The delivery scope of the machine includes the following items:

- Water management system C 400 V
- Filters
- Service Pack
- Double-bit key for control cabinet
- Key for key switch (only for units with positive locking control)
- These operating instructions

3.3 Return delivery after termination of a lease

For the protection of our customers and in terms of dangerous goods transport regulations, we must insist on the following return delivery conditions:

- As listed above
- Thoroughly cleaned (ready for use)
- Without residual fibre encapsulation
- Without filter
- Without damage

3.4 Operating modes

3.4.1 Available operating modes

Type of use

The machine is intended exclusively for use in the following types of use.

Other types of use is not in accordance with the intended use.

User groups

- Commercial users

User environment

- on roofed areas
- in rooms closed on all sides

Operating modes

Operating modes for use:

- Automatic mode
- Manual operation

3.5 Interfaces

This section contains information about interfaces.

The following interfaces are available on the machine:

Interfaces

- Man-product: Main switch, key switch, push-button
- Product power supply: Electrical power supply 400 V
- Product waste: Geka connection for filtered wastewater into the sewerage system
- Product material feed: Geka connection for contaminated shower water
- Product floor: castor wheels

3.6 Type plate

The type plate contains information for identifying the machine.

3.6.1 Version

Aluminium plate, riveted

3.6.2 Position

Near the control panel

3.7 Accessories

The following accessories are optionally available for Water management system:

Designation	Item no.	Illustration
Waste water hose 5m with Geka connection 3/4".	BU1504	
Fresh water hose 5m with Geka connection 1/2".	BU1504a	

4 Technical data

4.1 Dimensions

- Length: 806 mm
- Width: 488 mm
- Height: 839 mm

4.2 Mass

- Weight: 38 - 42 kg (depending on version)

4.3 Performance data

- Power connection: 400 V 32 A
- Pump capacity: 0,45 KW
- Output power instantaneous water heater: 21 KW
- Shower water flow rate: max. 10 l/min

4.4 Noise emission

- Normal operation At a distance of 1m from the unit: 65 dB (A)
- Short-time with active signal horn: 92 dB (A)



Wear hearing protection in the immediate vicinity of the Water management system.

5 Security

This section contains information on the protection of humans, domestic and farm animals and the environment.

5.1 Intended use

The machine is intended exclusively for the following use:

Intended use

When carrying out construction work in closed rooms, it is important to ensure that hazardous substances do not leave the construction area in an uncontrolled manner and thus pose a risk to people and the environment. For this reason, persons leaving the construction area via airlocks must shower when exiting.

The deconta Water management system heats the shower water and treats (filters) the contaminated wastewater.

The electronic flow heater, the wastewater pump and a 3-stage wastewater filter system are accommodated in the powder-coated aluminium housing.

The hot water output temperature of the shower water is infinitely variable with a maximum flow rate of 10 litres per minute.

The user must comply with the operating parameters specified in the operating instructions.

The unit may only be used in accordance with its intended purpose. Any other use beyond this is not in accordance with the intended use. The user is liable for any resulting damage or injury of any kind.

Authorised persons

The following persons are authorised to handle the product:

- Specialist staff
 - Task: Maintenance and servicing
 - Qualification: trained specialist personnel (locksmith, industrial mechanic, electrician) with knowledge and experience in handling the machine.
- Operating personnel
 - Task: Operation
 - Qualification: training, information through operating instructions

Any other use is not in accordance with the intended use.

Range of application

The machine is intended for use in the following applications:

Range of application

- Refurbishments

5.2 Misapplication

Use of the machine for the following purposes is not permitted:

Reasonably foreseeable misuse

- Any application other than that described in the operating instructions
- Any use of the machine other than that described under "Intended use" without the written consent of the manufacturer.
- Operation outside the technical limits of use
- Unauthorised modifications or conversions as well as manipulation
- Use, installation, operation, maintenance or repair in a manner other than described
- Carrying out work by unqualified personnel
- Use of unsuitable or incompatible materials, operating or auxiliary materials or accessories.
- Non-compliance with safety and operating instructions, occupational health and safety or accident prevention regulations or relevant statutory regulations.
- Failure to promptly rectify faults that may affect safety
- Use of other than original spare parts or accessories that are not equivalent in quality and function.
- Operating the machine in a technically unsound condition, not being aware of safety and hazards and not observing all instructions in the documentation.
Use in potentially explosive atmospheres

5.3 Tasks and qualifications of the staff

Person	Task	Required qualification
Operator	<< Machine-specific >>	Instruction, training
Programmer	Machine teaching, programming	Knowledge of programming and teaching machines or robots
Occupational safety specialist	<ul style="list-style-type: none"> • Carry out a risk assessment • Create operating instructions • Instruct people 	Completed training as an occupational safety specialist with timely experience with machines
Electrician	Installation and maintenance of electrical equipment	Person with appropriate training, suitable education, timely experience and knowledge of the relevant regulations, enabling him/her to recognise risks and avoid hazards that may be caused by electricity.
Freight forwarder	Off-site transport of the machine	Person with suitable training, education, timely experience and knowledge of relevant regulations that enables them to safely transport machinery off-site.
Conveyor	Internal transport of the machine	Person with appropriate training, education, timely experience and knowledge of the relevant regulations that enables them to safely transport machinery within the company.
Disposer	Dispose of machine	Qualified waste management company for legally compliant, proper and professional disposal of the machine

5.4 Notes on occupational health and safety

The operator of the machine is responsible for the implementation of the occupational health and safety obligations. The health and safety regulations of the country in which the machine is used apply.

The duties include, but are not limited to, the following:

- Make these operating instructions or extracts available to persons who carry out tasks with or in connection with the machine.
- Make the applicable documents available to these persons
- Instruction of the persons with regard to the intended use and misuse
- Instruction of persons with regard to protective devices and supplementary protective devices
- Instruction of persons with regard to residual risks

This list is not exhaustive and does not claim to be complete.

6 Transport

This section contains information on transporting the machine outside and inside the factory.

Transport is the change of location of the machine by manual or technical means.

HINWEIS

In winter, because of the danger of frost, urgent attention should be paid:

Drain water pipes, filter housings and pumps

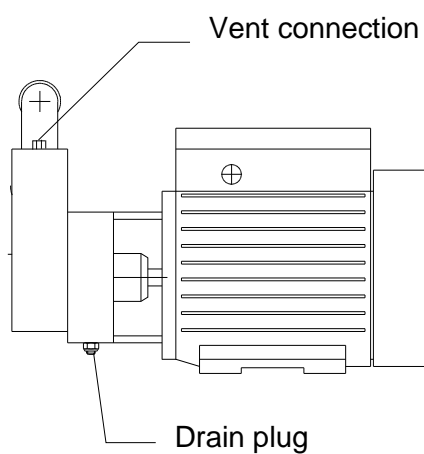

6.1 Loss of warranty claims

The manufacturer's warranty will expire in the following cases:

- In the event of modifications to the machine that have not been agreed with the manufacturer
- If the transport is not carried out properly

6.2 Off-site transport

6.2.1 Transport space

Off-site transport takes place in the public space. In this case, the machine is transported from one place of use to another.

6.2.2 Legislation

Off-site transport of the machine shall be in accordance with the legislation of the country in which the machine is transported off-site.

6.2.3 Qualification of the staff

Persons transporting the machine outside the company must meet the following requirements:

Person	Required qualification
Freight forwarder	Completed training in transport and experience in off-site transport of machinery
Logistician	Completed training and experience in the internal transport of machines

6.2.4 Warning of residual risks



Crushing hazard: Wear safety shoes to protect against running over limbs.

6.2.5 Means of transportation

For safe off-site transport, a means of transportation is required that meets the following requirements:

- The load capacity must be dimensioned in such a way that the mass of the machine can be safely accommodated.
- The size of the transport surface must be such that the machine can be safely placed on the transport surface without falling off.



Falling of the machine may be possible due to unintentional change of position when loading and unloading onto / from a means of transportation.

6.3 Internal transport

6.3.1 Transport space

In the case of in-plant transport, the machine is transported on the company premises from one installation site to another installation site.

6.3.2 Legislation

The internal transport of the machine is carried out in accordance with the legislation of the country in which the machine is transported outside the company.

6.3.3 Warning of residual risks



Crushing hazard: Wear safety shoes to protect against running over limbs.

6.3.4 Means of transportation

For safe internal transport, a means of transportation is required that meets the following requirements:

- The load capacity must be dimensioned in such a way that the mass of the machine can be safely accommodated.
- The size of the transport surface must be such that the machine can be safely placed on the transport surface without falling off.



Falling of the machine may be possible due to unintentional change of position when loading and unloading onto / from a means of transportation.

7 Assembly

This section contains information on the safe assembly of the machine.

The Water management system is delivered ready for operation ex works and is intended for immediate commissioning.

If there is visible damage, **do not** operate the unit. Contact deconta GmbH immediately.

8 Put into operation

This section contains information on commissioning the machine.

HINWEIS

For versions without control unit, it is essential to observe the positive locking:

To prevent damage to the heating coil in the instantaneous water heater, it is essential to observe the following points during initial commissioning / initial filling:

- Make hose connections as described on the following page
- Switch off main switch
- Start water supply and wait until water comes out in the shower
- Switch on main switch
- the unit is now ready for operation

Before initial commissioning or after a longer standstill, check whether the shaft of the pumps can be turned by hand. To do this, insert a screwdriver into the notch at the end of the shaft and move the shaft. The high initial resistance to rotation of the impeller in new pumps will loosen after running-in.



8.1 Version with one wastewater pump / with forced locking



- Make hose connections:
 - Connecting the "water inlet" connection to the mains supply
 - Connecting "hot shower water" to the shower roof
 - Connect "wastewater IN" connection to shower floor
 - Connect the "wastewater OUT" connection to the sewage system
- Fill wastewater pump with water
- Fill the filter housing of the 220 μ filter with water.
- Hand-tighten the union nuts of the filter housings
- Establish power connection

8.2 Version with 2 wastewater pumps for 2nd shower



- Pull out the mains plug
- Make hose connections:
 - Connecting the "water inlet" connection to the mains supply
 - Connecting "Hot water shower 1" with shower roof
 - Connect the "Cold water shower 1" connection to the cold water connection on the shower roof (if available).
 - Connecting "Hot water shower 2" with shower roof
 - Connect the "Cold water shower 2" connection to the cold water connection on the shower roof (if available).
 - Connect connection "wastewater IN 1" with shower floor
 - Connect connection "wastewater IN 2" with shower floor
 - Connect the "wastewater OUT" connection to the sewage system
- Fill wastewater pump with water
- Fill the filter housing of the 220µ filters with water
- Hand-tighten the union nuts of the filter housings
- Establish power connection

8.3 Version with control compulsory locking

- Hose connections, as described under 8.1 Make hose connections as described under 8.1
- Switch off main switch
- Set the circuit breaker for the instantaneous water heater inside the appliance to "0".



- Switch on main switch
- Press the "Shower water start" button and keep it pressed (button lights up) until water flows out of the shower.
- Switch off main switch
- Set the circuit breaker for the instantaneous water heater inside the appliance to "1".
- Switch on main switch

8.3.1 Switching on the positive locking

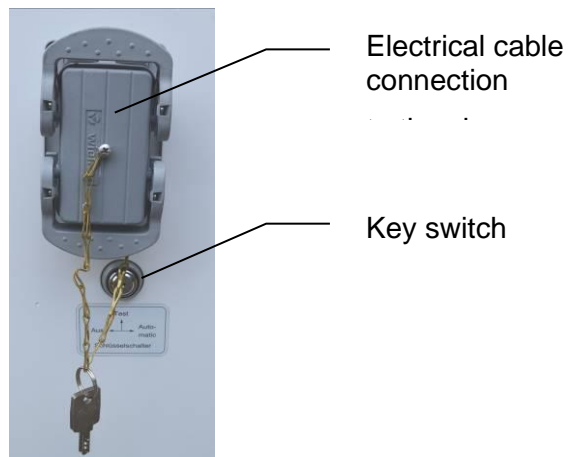

- Connect electric cables to the Water management system and to the shower roof of the personnel lock.
- Make sure that both doors to the shower room of the personnel lock are closed.
- Set the key switch to the "Test" position, the green buttons of the door boxes in the personnel interlock light up. After approx. 5 seconds, switch to the "Automatic" position, the positive locking is now activated, the green buttons on the door boxes remain lit.

9 Operation

This section contains information for the safe use of the machine.

9.1 Qualification of the staff

Persons using the machine must meet the following requirements:

Person	Required qualification
Operator	Instruction, training by the manufacturer

9.2 Warning of residual risks



Touching the cores of a damaged mains connection cable.

Touching machine parts that have become live due to faulty conditions.

Only operate the unit on mains supplies that are protected by residual current circuit breakers!



Damage due to unsuitable mains voltage.

The unit may be damaged if it is connected to an unsuitable mains voltage.

Check whether the voltage indicated on the type plate corresponds to the local mains voltage.



Preset temperature (approx. 37°C). Do not change the settings on the temperature setting knob of the instantaneous water heater. Danger of scalding!

Check the outlet temperature before every shower!



Temperature setting knob

9.3 Personal protective equipment required

The following personal protective equipment is required for the use of the machine:

- Hearing protection in the immediate vicinity, if necessary

9.4 Number of persons

One person is needed to use the machine.

9.5 Tools needed

No tools are needed to use the machine.

9.6 Required equipment

No equipment is needed to use the machine.

9.7 Commissioning after triggering the safety temperature and pressure limiter

The heating elements are heating coils that are directly washed by the water flowing through them. This type of heating and the extremely low water content of 0.5 litres ensure a high degree of efficiency. The water flow is limited to a maximum of 10 l/min by a built-in flow regulator when the hot water valve is fully open, so that an outlet temperature suitable for showering is maintained.

The built-in safety temperature and pressure limiter provides a double safety shutdown in case of overpressure and overtemperature.

The pressure limiter is triggered when the pressure rises to approx. 22 bar, the temperature limiters are triggered at approx. 55° C in the inlet and at approx. 70° C in the hot water outlet. If the pressure or temperature limiter responds, the unit is immediately disconnected from the mains.

Before repressing the safety temperature and pressure limiter, the cause of the malfunction must be determined and rectified by a specialist.

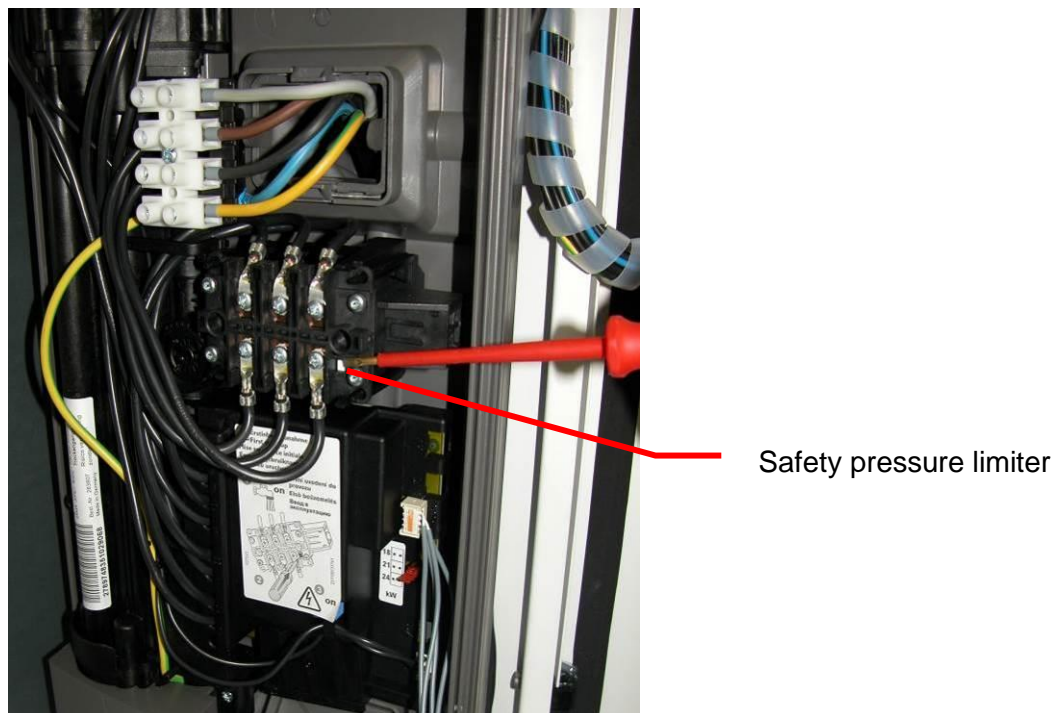

- (1) Switch off the mains voltage.
- (2) Remove the cover from the instantaneous water heater. Note the slot of the potentiometer.
- (3) Use a screwdriver to press on the pressure point of the limiter (see picture) until it engages.
- (4) If necessary, put the potentiometer back on and attach the cover.
- (5) Switch on the mains voltage.

10 Maintenance

This section contains information for the safe maintenance of the machine.

Maintenance includes all technical and organisational measures during the life cycle of the machine to ensure the safe, economical and functional condition of the machine and to prevent environmental damage.

10.1 Loss of warranty claims

The manufacturer's warranty is void in the following cases:

- In the event of changes to the machine that have not been agreed with the manufacturer
- In the event of improper performance of maintenance

10.2 Maintenance

Maintenance work, including changing / removing the filters, may only be carried out by authorised persons wearing suitable protective clothing.

For all repair and maintenance work, the unit must be completely disconnected from the power supply.

We expressly refer to possible additional regional and national regulations when maintaining the appliance technology.

10.2.1 Warning of residual risks



Contaminated filters may only be changed in compliance with all relevant safety precautions. Change filters only when the unit is switched off. Only use approved filters.



Pull out the mains plug before opening the housing

10.2.2 Personal protective equipment required



Maintenance work, including changing / removing the filters, may only be carried out by authorised persons wearing suitable protective clothing.

10.3 Daily maintenance

- Checking the water pipes for free flow
- Visual inspection of the 220µ pre-filters for contamination
- Control of the fine filters via pressure gauge

10.4 Filter change

The fine filters are monitored via the pressure gauge. We recommend changing the filter at approx. 3bar.

Attention:

- Filter change only when the unit is switched off
- Remove dirty filters when damp to prevent the release of filter dust.
- Only use approved filters
- Damaged filter cartridges must not be used



Filter change:

- Loosen the union nut with the help of the filter head spanner
- Remove the filter and dispose of it in accordance with the regulations
- Insert new filter cartridges
- Make sure that the sealing ring is correctly seated and clean.
- Tighten the union nut **hand-tight**



Suction hoses, pumps, filter housings and filters are already contaminated by the initial use. Repairs and maintenance work may only be carried out in compliance with all relevant safety measures.

The filters must be disposed of in accordance with the legal requirements.

11 Spare parts

For safe, trouble-free and economical use of the machine, original spare parts should be used.

If this is not possible, the alternative spare parts should correspond to the characteristics of the original spare parts in order to ensure the safe, trouble-free and economical use of the machine.

11.1 Water management system C 400 V Type 557

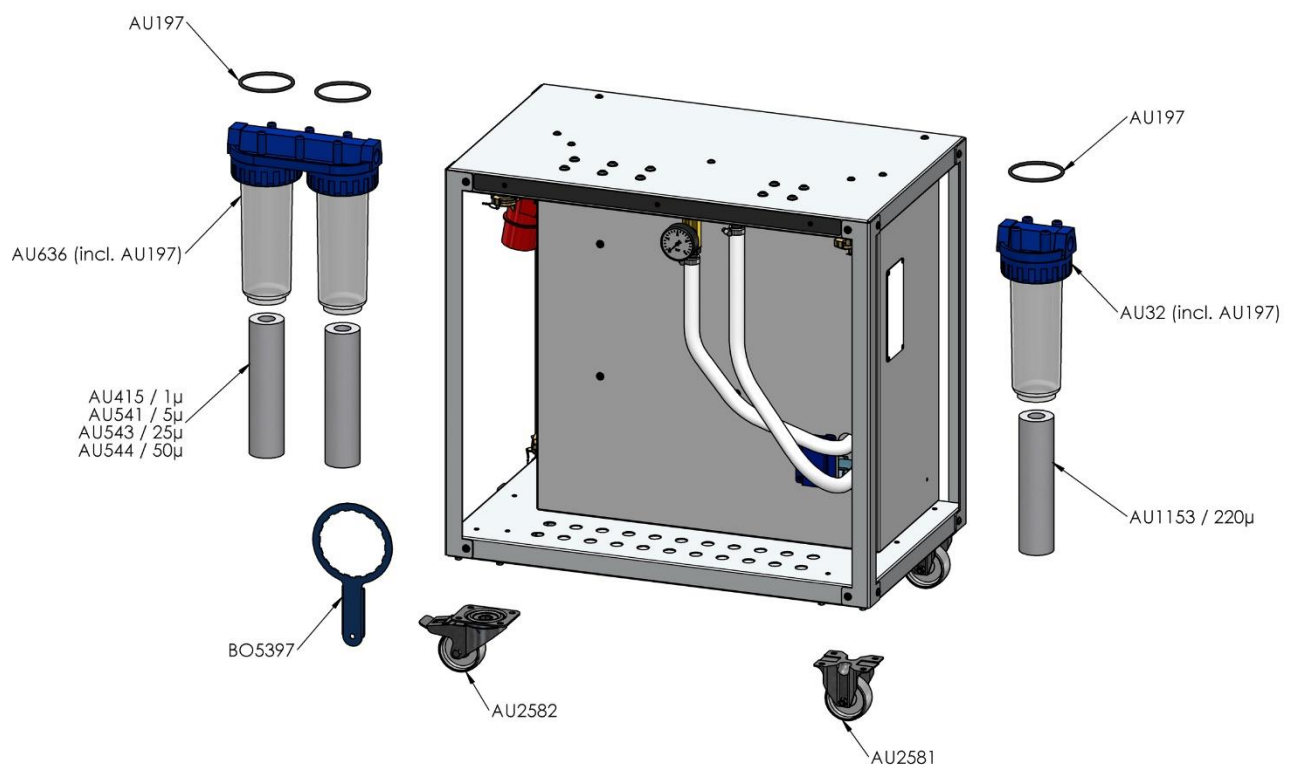

11.2 Water management system C 400 V Type 558 with positive locking

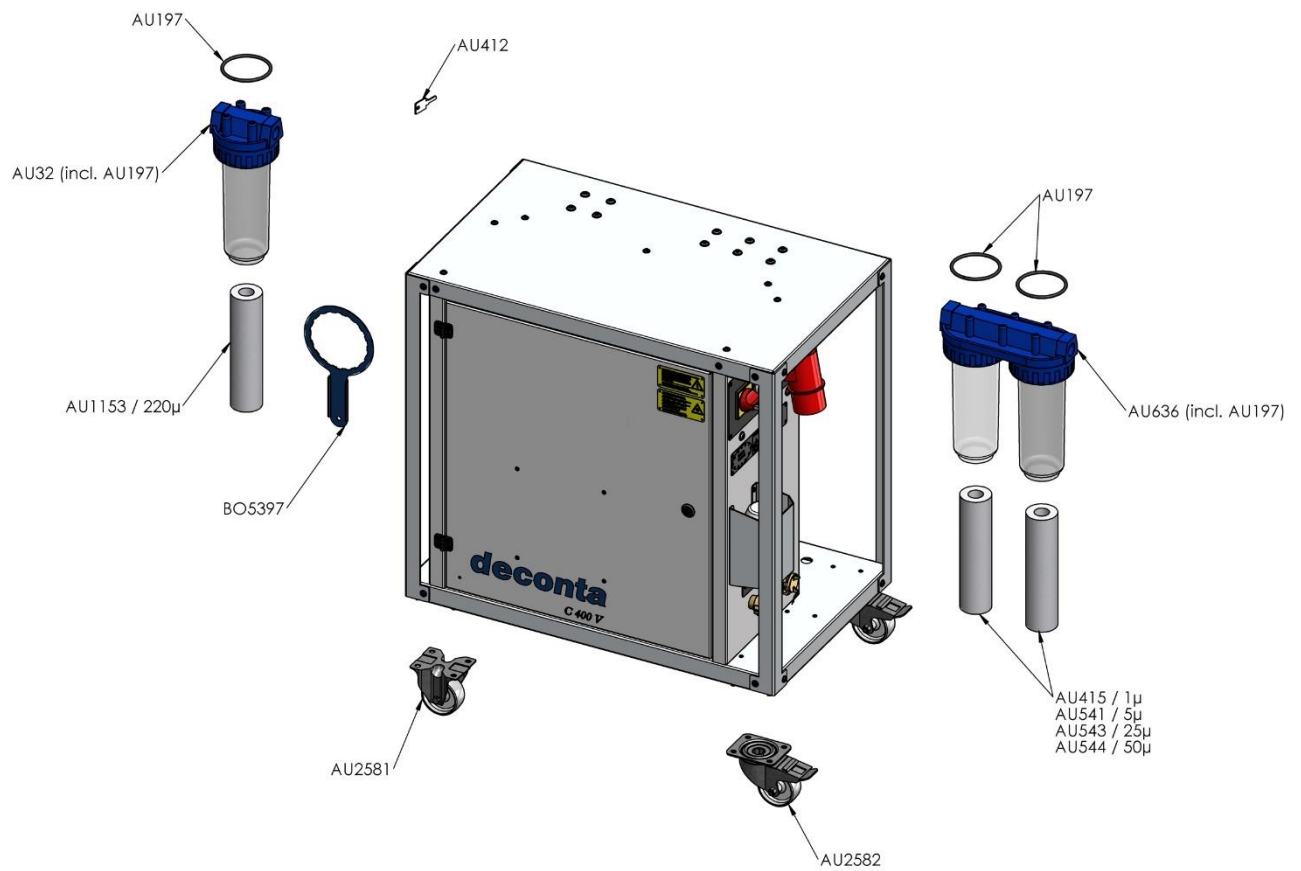

11.3 Water management system C 400 V type 562 with 2 wastewater pumps

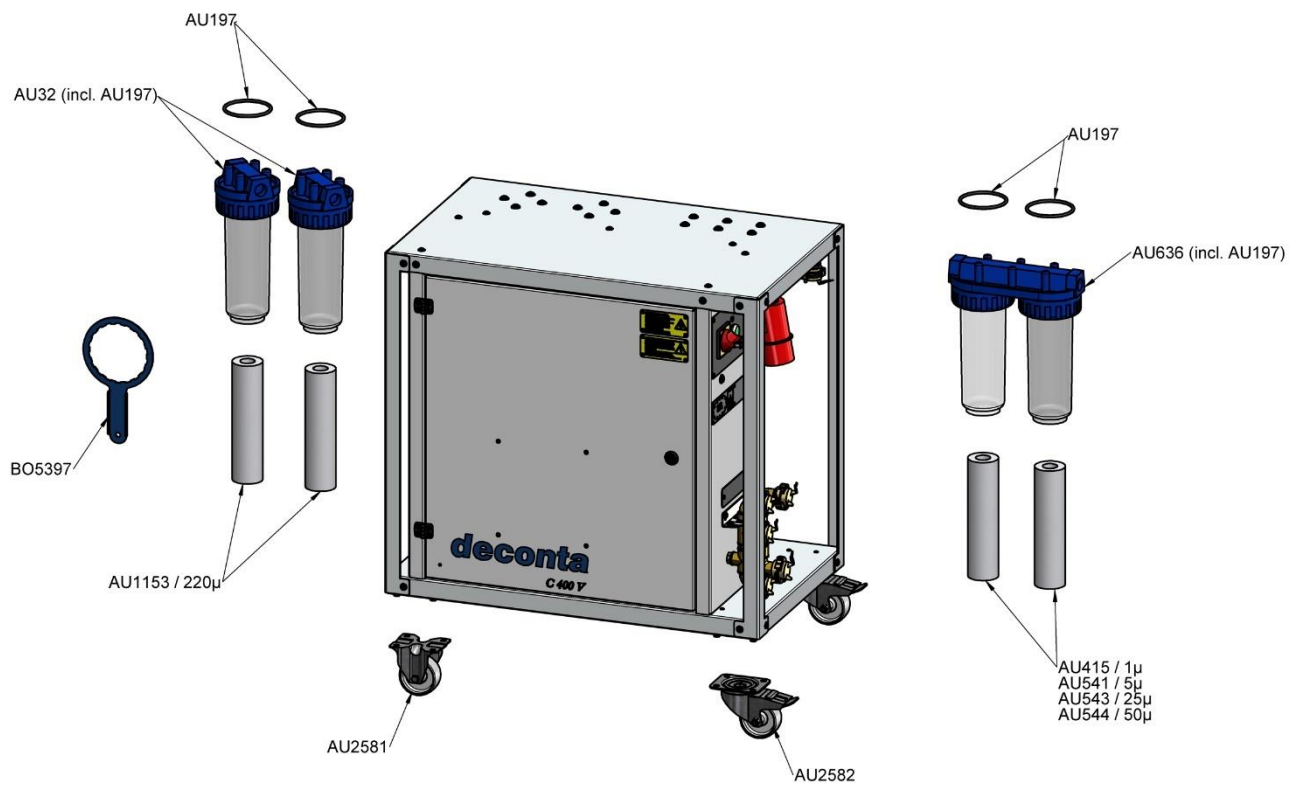

13 **Cleaning**

The appliance must be cleaned and rinsed before each use (including first use). This also applies to the optionally available water hoses.

After use, the hoses must be carefully rinsed, disinfected and completely emptied or dried.

14 **Storage**

To avoid damage, the unit must only be stored in dry rooms that are inaccessible to unauthorised persons.

HINWEIS

In winter, because of the danger of frost, urgent attention should be paid:

Drain water pipes, filter housings and pumps

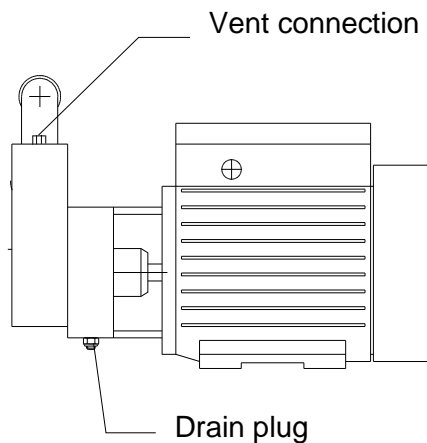

The optional hoses may only be stored completely emptied and in a hygienic condition!

During storage, make sure that contamination with other substances is excluded. Drinking water hoses (fresh water hoses) and waste water hoses must be stored separately.

15 Disposal

Disposal is the capturing, collecting, forming, selecting, processing, regenerating, destroying, recycling and selling of the materials to be disposed of that are built into the machine.

This section contains information on the proper and professional disposal of the machine.

15.1 Qualification of the staff

Persons disposing of the machine must meet the following requirements:

Person	Required qualification
Disposer	Qualified waste management company for legally compliant, proper and professional disposal of the machine

15.2 Legislation

Disposal of the machine shall be in accordance with the legislation of the country where the machine is disposed of.

Compliance with these legal regulations is basically the responsibility of the operator of the machine or the person in charge of disposal.

15.3 Waste

The waste generated by the machine must be disposed of in a legally compliant, proper and professional manner.

16 EC Declaration of Conformity

The manufacturer / distributor

deconta GmbH
Im Geer 20
46419 Isselburg

hereby declares that the following product

Product designation: C 400 V
Type designation: 557, 558, 562
Serial number: see type plate
Trade name: Water management system C 400 V
Year of manufacture: see type plate
Description: Water management system C 400 V

complies with all relevant provisions of the applied legal regulations (hereinafter) - including their amendments in force at the time of the declaration. The sole responsibility for issuing this declaration of conformity lies with the manufacturer. This declaration relates only to the machine in the condition in which it was placed on the market; parts and/or interventions subsequently fitted by the end user are not taken into account.

The following legislation was applied:

Machinery Directive 2006/42/EC
RoHS Directive 2011/65/EU

The protection goals of the following additional legal regulations were met:

Low Voltage Directive 2014/35/EU

The following harmonised standards were applied:

EN 60204-1:2018	Safety of machinery - Electrical equipment of machines - Part 1: General requirements (IEC 60204-1:2016 (Modified))
EN ISO 12100:2010	Safety of machinery - General principles for design - Risk assessment and risk reduction (ISO 12100:2010)
EN ISO 13849-1:2015	Safety of machinery - Safety-related parts of control systems - Part 1: General principles for design (ISO 13849-1:2015)
EN ISO 13849-2:2012	Safety of machinery - Safety-related parts of control systems - Part 2: Validation (ISO 13849-2:2012)
EN ISO 13857:2019	Safety of machinery - Safety distances to prevent hazard zones from being reached by the upper and lower limbs (ISO 13857:2019)

Name and address of the person authorised to compile the technical file:

Boland, Thomas - deconta GmbH, Im Geer 20 - 46419 Isselburg

Place: Isselburg Date : 27.04.2023

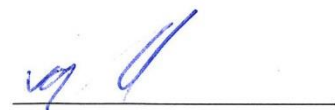

Leiter Konstruktion / head of construction



Leiter Elektro / head of electro